

KALEA A4 CABINA



- A Cabin lift for installation in existing brick/concrete shaft
- Elegance and comfort with sliding doors and auto-run operation
- Soft start and stop and electrical emergency lowering as standard
- Integrated machine room
- An integrated mirror on the lift car wall
- Engine noise is insulated for a quiet ride
- Quick installation time within 3-4 days
- Swedish design and quality
- Robust and reliable screw driven operation
- Energy efficient and low maintenance operation system
- Push buttons with tactile symbols
- Control panel with emergency lightning system
- Rated load 400 kg, 5 people
- Travel height 13 metres, 6 landings
- 70 mm pit

The ideal cabin lift solution

Kalea A4 Cabina is a shaftless cabin, carefully designed to be mounted in existing shafts in all type of buildings.

Kalea A4 Cabina is a screw-driven prefabricated cabin lift, designed to fit into existing lift shafts. All elements of the lift are prefabricated and ready to install and you do not need to worry about extensive construction work.

The pit depth is reduced to 70 mm and the machine room is fully integrated. Everything you need fits into the existing shaft, making the Kalea A4 Cabina an exceptionally space efficient solution. The cabin is elegant and spacious, fully equipped for comfort with sliding doors and auto-run controls.

Fast to install and easy to maintain

Thanks to the smart engineering and construction of the Kalea A4 Cabina, a 2 stop lift can be installed within 3-4 days. In addition, the robust and reliable screw driven system of the Kalea A4 Cabina mean low maintenance cost.



KALEA A4 CABINA

Standard size, mm

Cabin size (WxDxH): 1100x1400x2200

Min dimension shaft single entry (WxD): 1530x1670

Min dimension open through (WxD): 1530x1780

The exact cut out sizes vary depending on the configuration of the lift, and site specifications, please consult your local distributor for more information.

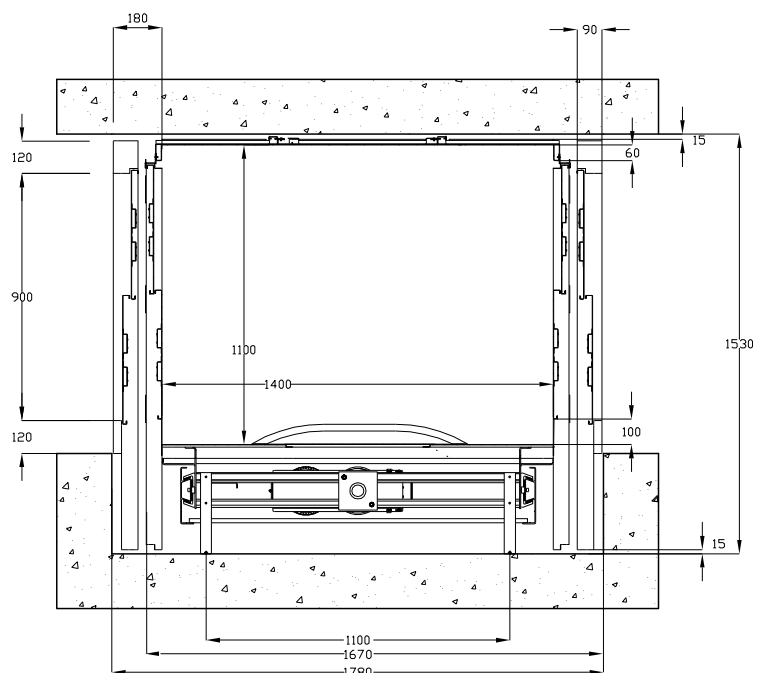



TECHNICAL INFORMATION	KALEA A4 CABINA
Lift location	Indoors
Rated load	400 kg
Rated speed (m/sec)	Max 0.15
Travel height	Up to 13 m
Maximum number of stops	6
Min.headroom at top landing	2700 mm
Pit depth without ramp	70 mm
Cabin size (WxDxH)	1100x1400x2200 mm
Min dimension shaft single entry (WxD)	1530x1670 mm
Min dimension open through (WxD)	1530x1780 mm
Standard cabin finish	Steel panels, white RAL 9016
Landing doors	Telescopic, RAL 9016
Cabin doors	Telescopic, RAL 9016
Cabin door opening size	900x2100 mm
Driving system	Screw and nut
Control system	CANbus microcomputer system
Standard power supply	3x400VAC/3x230VAC 50/60 Hz 16 A
Motor power	4 KW
Control buttons	Impuls control
Machine room	Integrated
In compliance	European MD 2006/42/EC and applicable parts of EN 81-41 and EN 81-70
Manufactured in	Sweden



For more product details and information about the product and accessory selection, contact Kalea Lifts AB. This product information is general and we reserve the right to modify product design and specifications. No claims shall be construed as warranties or conditions, express or implied, of any product, its fitness for a particular purpose or quality. Minor deviations in color reproduction can occur.
© Kalea Lifts AB 2014



KALEA A4 CABINA

ACCESSORY AND OPTION

Our standard lifts meet the most common requirements and needs that may exist on the market. Your lift can be customized to fit your specific requirements with our wide range of accessories and options.

ACCESSORIES

LOCKING SYSTEM

- School lock system at the landing doors (call button, key lock)
- Key lock on door
- Code lock with on/off function in the cabin
- Code lock on/off function at landing doors

TELEPHONE

- Intercom
- GSM module

ALARM

- Alarm signal
- Possibility to connect a remote alarm device
- Alarm beacon

FLOOR

- Non-slip rubber carpet
- Floor without carpet (for possibility to place flooring of own choice)
- Ramp

ACCESSORIES

CABIN

- Control panel in stainless steel or any RAL color
- Automatic light system
- Mirror

DOOR

- Externally fitted, elbow call button
- Powder coated door & frame in any RAL colour
- Fire rated doors E120
- Remote call button
- Level indicator on door front

EXTRA FUNCTION

- Infrared remote control, max 4 landings
- Arrival signal
- Voice announcer
- Fire drive
- Emergency lowering from inside
- Wall socket outlet in the electrical compartment



Externally fitted, elbow door call button



Numerical code lock

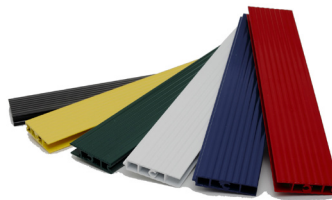

Any RAL colors



Intercom