



Aritco 4000 Living collection



Aritco 4000 - our smallest and most cost effective home lift

The lift has been designed to meet all requirements for comfort, space and design. The lift is available in several different sizes, with an option to personalise it with details such as glass walls, a range of varied colours and different materials.

Several advantages offered by Aritco 4000:

- Design, sizes and options created for a home environment
- Minimum interventions in the house
- 95% recyclable materials
- 'A' rated energy consumption according to VDI4707
- Patented screw/nut technology (no oil that can leak)
- Requires minimum maintenance
- The lowest maintenance and operating costs on the market

Aritco 4000

Living collection



Length

Width

580 x 805

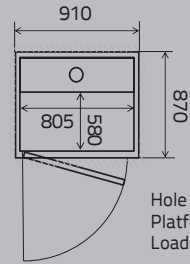

Hole through floor: 870x910 mm
Platform: 580x805 mm
Load: 250 kg

880 x 805

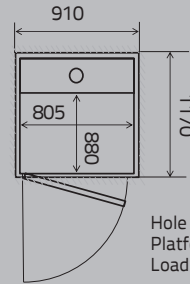

Hole through floor: 1170x910 mm
Platform: 880x805 mm
Load: 250 kg

1080 x 805

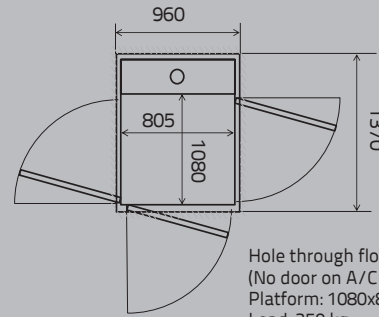

Hole through floor: 1370x960 mm
(No door on A/C side: 1370x910)
Platform: 1080x805 mm
Load: 250 kg

Dimensions

Platform width 580-1080 mm
Platform length 805 mm
Travel height..... 250-13000 mm

Hole through floor width.....870-1370 mm
Hole through floor length.....910-960 mm
Top height2300 mm

Height of door opening1800, 1900, 2000 mm
Width of door opening.....800, 900 mm

Drive system: Patented screw/nut system

Rated speed: max. 0.15 m/s

Platform control: "Hold to run", the button has to be kept pressed during the ride

Landing control: One-touch call

Technical compliance: European Machinery Directive 2006/42/EC
European standard EN 81-41

Rated load: 250 kg / 2 persons

Number of stops: max. 6

Number of doors: max 2 doors per floor

Pit: 50 mm (no pit is required when there is a threshold)

Environment: Indoors

Power supply: 1-phase 230V 50Hz/6.6A/16A slow

Emergency lowering: Battery-powered

Control voltage: 24 V

Motor: 1.5 kW

For more information, please, refer to our product catalogue or visit our website.

Due to the continuous product development at the company, the information may change without prior notice.